

鋼管用

MCF

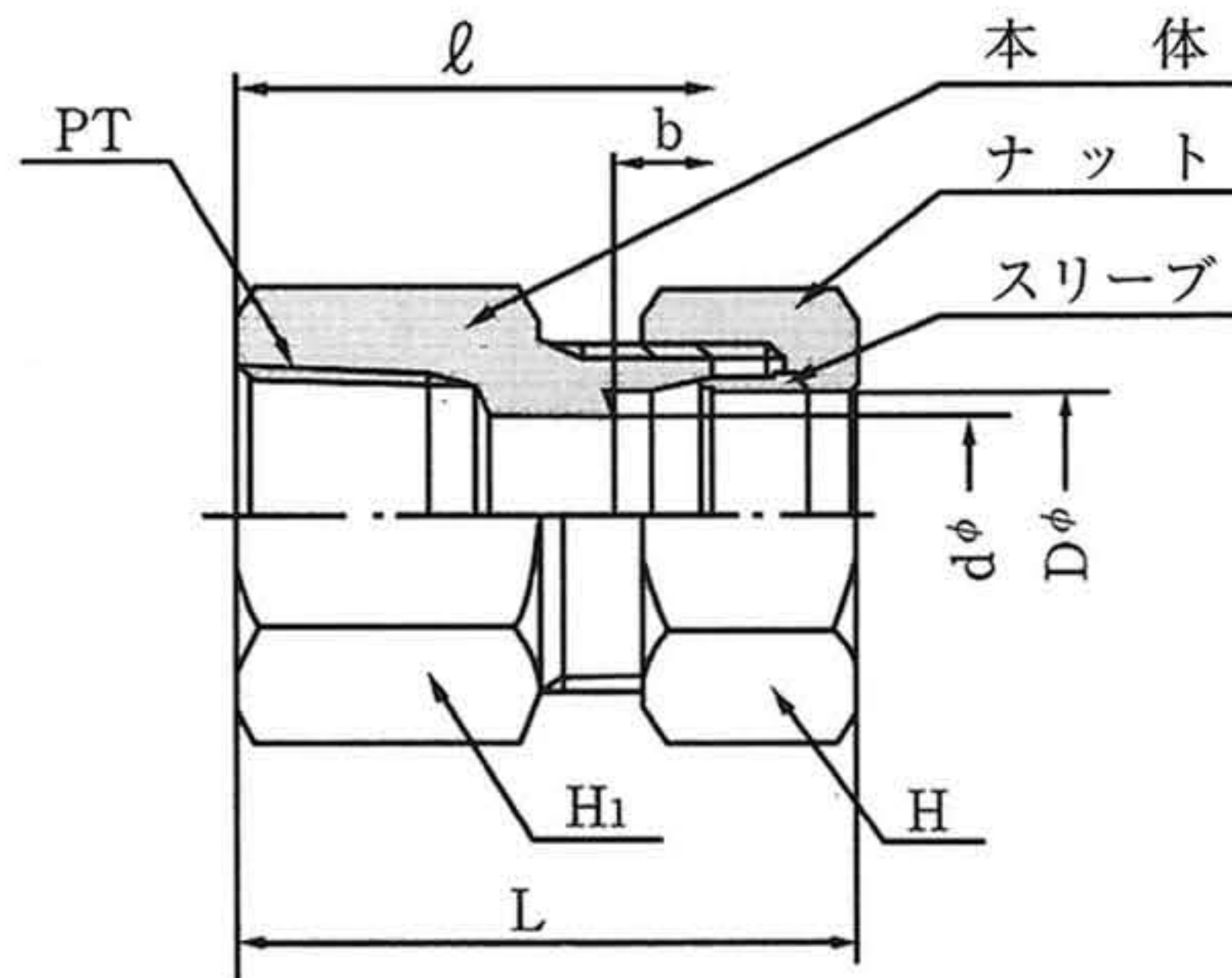

単位：mm

継手の呼び方	適用する管の外径 D		d	六角対辺		b	ℓ	(約) L	PT
	呼び	外径		H ₁	H				
MCF 6-PT 1/8	6	6	4	17	14	7	25	35.5	1/8
MCF 6-PT 1/4	6	6	4	17	14	7	30	35.5	1/4
MCF 6-PT 3/8	6	6	4	22	14	7	32	43.5	3/8
MCF 8-PT 1/4	8	8	6	17	17	7	30	40.5	1/4
MCF 8-PT 3/8	8	8	6	22	17	7	32	41	3/8
MCF 10-PT 1/4	10	10	8	17	19	7	30	41.5	1/4
MCF 10-PT 3/8	10	10	8	22	19	7	32	43.5	3/8
MCF 12-PT 1/4	12	12	10	19	22	7	30	41.5	1/4
MCF 12-PT 3/8	12	12	10	22	22	7	32	43.5	3/8
MCF 15-PT 3/8	15	15	12	24	27	7.5	34	46.5	3/8
MCF 15-PT 1/2	15	15	12	30	27	7.5	39	51.5	1/2
MCF 16-PT 1/2	16	16	13	30	30	7.5	39	51.5	1/2
MCF 18-PT 3/8	18	18	12	24	32	8	39	51.5	3/8
MCF 18-PT 1/2	18	18	14	30	32	8	39	51.5	1/2
MCF 20-PT 1/2	20	20	14	30	36	8	41	51.5	1/2
MCF 20-PT 3/4	20	20	17	36	36	8	41	53.5	3/4
MCF 22-PT 1/2	22	22	18	30	36	9	41	51.5	1/2
MCF 22-PT 3/4	22	22	18	36	36	9	41	53.5	3/4
MCF 25-PT 1	25	25	20	46	41	10	45	58.5	1
MCF 28-PT 1	28	28	22	46	46	10	47	61	1
MCF 30-PT 1	30	30	25	46	46	10	47	61.5	1
MCF 1/8-PT 1/4	1/8	10.5	8	19	49	7	30	41.5	1/4
MCF 1/4-PT 3/8	1/4	13.5	11	24	24	7.5	34	46	3/8
MCF 3/8-PT 1/2	3/8	17.3	14	30	32	8	39	51.5	1/2
MCF 1/2-PT 3/4	1/2	21.7	18	36	36	9	41	53.5	3/4
MCF 3/4-PT 1	3/4	27.2	22	46	46	10	47	61	1

(但し、素材の都合に依り多少寸法が変わることがあります。)