

ニップル

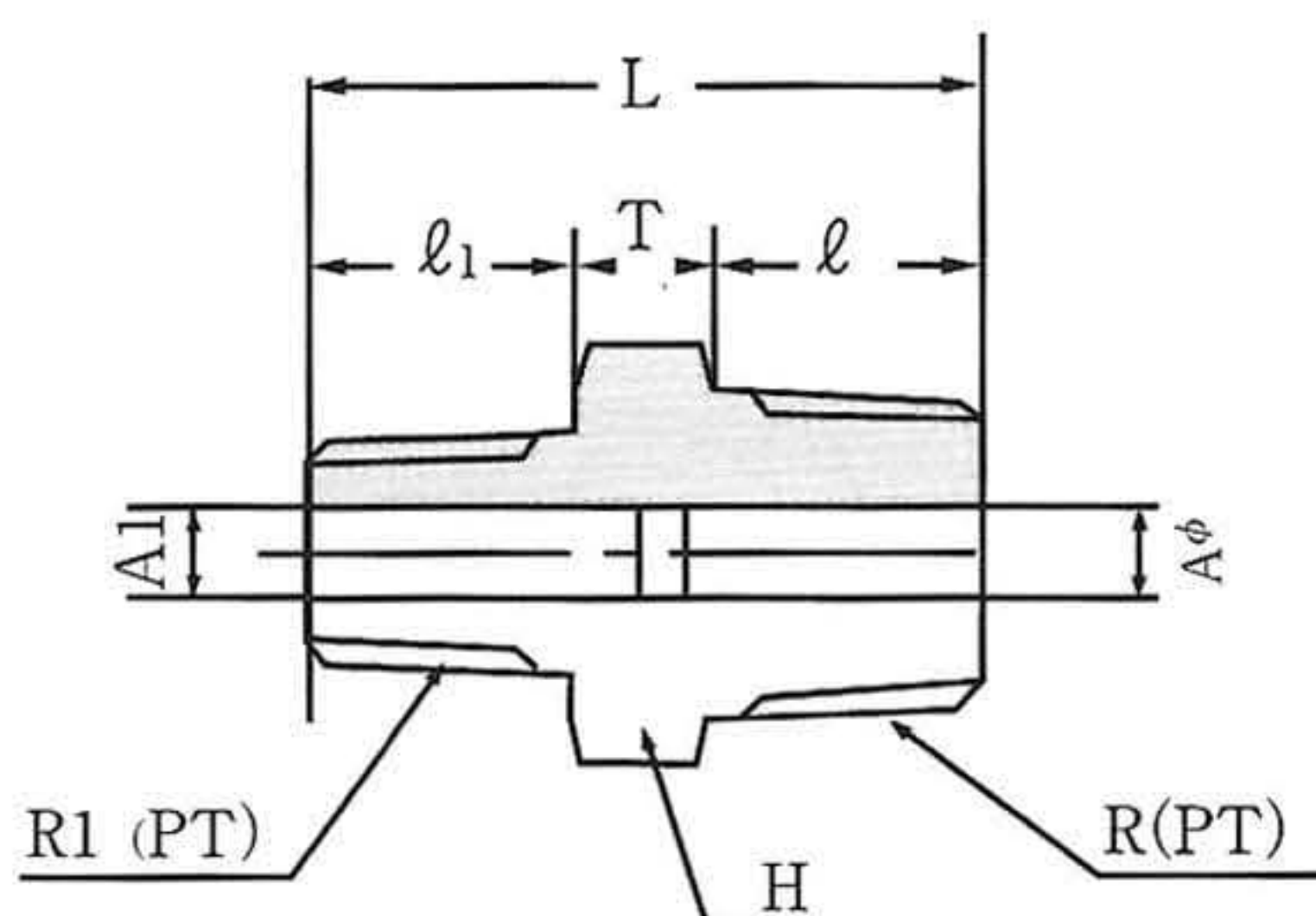

異径ニップル

※ (S/80)

単位：mm

継手の呼び方	(約) L	T	ℓ	六角対辺 H	A
PT 1/8	24	6	9	14	4
PT 1/4	34	8	13	17	7
PT 3/8	36	8	14	19	9
PT 1/2	43	9	17	24	12
PT 3/4	48	10	19	30	16
PT 1	53	11	21	36	20
PT 1 1/4	60	12	24	46	28
PT 1 1/2	64	14	24	50	30
PT 2	72	16	28	63	40
PT 2 1/2	82	18	32	77	55
PT 3	90	20	35	90	65

※ (S/80)

単位：mm

呼称	T	ℓ	ℓ1	(約) L	六角対辺 H	A	A1
PT 1/4 × 1/8	8	13	10	31	17	5	5
PT 3/8 × 1/4	8	14	13	35	19	7	7
PT 1/2 × 1/4	9	17	13	39	24	7	7
PT 1/2 × 3/8			14	40		9	9
PT 3/4 × 1/8	10	19	13	42	30	7	7
PT 3/4 × 3/8			14	43		9	9
PT 3/4 × 1/2			17	46		12	12
PT 1 × 3/8	11	21	14	46	36	9	9
PT 1 × 1/2			17	49		12	12
PT 1 × 3/4			19	51		16	16
PT 1 1/4 × 1/2	12	24	17	53	46	28	13
PT 1 1/4 × 3/4			19	55		20	16
PT 1 1/4 × 1			21	57		20	20
PT 1 1/2 × 3/4	14	24	19	57	50	30	16
PT 1 1/2 × 1			21	59		28	20
PT 1 1/2 × 1 1/4			24	62		28	28
PT 2 × 1	16	28	21	65	63	40	20
PT 2 × 1 1/4			24	68		30	28
PT 2 × 1 1/2			24	68		30	30

※このページの管継手は接続される鋼管の厚さがSCH80又はSCH40以下とします

(但し、素材の都合に依り多少寸法が変わることがあります。)